

## Section 7. Hammer Lug Unions

Hammer Lug Unions are designed and manufactured in accordance with the following specifications:-

<b>API 6A</b>	Specification for Wellhead and Christmas Tree Equipment.
<b>API RP-14E</b>	Recommended Practice for Design and Installation of Offshore Production Platform Piping
<b>NACE MR-01-75</b>	Sulphide Stress Cracking Resistant Metallic Materials for Oilfield Equipment.
<b>ASME VIII</b>	Boiler and Pressure Vessel Code.
<b>ANSI B31.3</b>	Chemical Plant and Petroleum Refinery Piping.

Hammer Lug Unions are available in a range of figure numbers for use with the following pressure ratings and services:-

FIGURE No:	100	200	206	400	602	1002/1004*	1003	1502	2202
<b>STANDARD SERVICE</b>									
Max. Working Pressure	1,000 PSI	2,000 PSI	2,000 PSI	4,000 PSI	6,000 PSI	10,000 PSI	10,000 PSI	15,000 PSI	N/A
Max. Test Pressure	1,500 PSI	3,000 PSI	3,000 PSI	6,000 PSI	9,000 PSI	15,000 PSI	15,000 PSI	22,500 PSI	N/A
Colour Code	Subs - Yellow Nut - Black	Subs - Grey Nut - Blue	Subs - Grey Nut - Blue	Subs - Red Nut - Black	Subs - Orange Nut - Black	Subs - Blue Nut - Red	Subs - Green Nut - Black	Subs - Red Nut - Blue	N/A
<b>SoUR SERVICE</b>									
Max. Working Pressure	N/A	N/A	N/A	4,000 PSI	6,000 PSI	7,500 PSI	7,500 PSI	10,000 PSI	15,000 PSI
Max. Test Pressure	N/A	N/A	N/A	6,000 PSI	9,000 PSI	11,250 PSI	11,250 PSI	15,000 PSI	22,500 PSI
Colour Code	N/A	N/A	N/A	Subs - Green Nut - Green	Subs - Green Nut - Green	Subs - Green Nut - Green	Subs - Green Nut - Green	Subs - Green Nut - Green	Subs - Green Nut - Green

GENERAL NOTE: Please contact GonPetro for any special material or dimensional requirements. Sizes 5" to 12" Fig 400 - 2500 PSI MWP, 3750 PSI MTP.

\* NOTE: 1002 5" & 6" unions available in both O-Ring (1002) and Lipseal design (sometimes referred to as 1004). Special sizes & configurations are available in 1502 & 1002/1004, please contact GonPetro. 5" and 6" Fig 1002 Unions down-rated to 5,000psi WP (10,000psi TP) for Sour Gas Service, and 7,500 psi WP (11,250 TP) for Standard Service.

## Section 7. Hammer Lug Unions

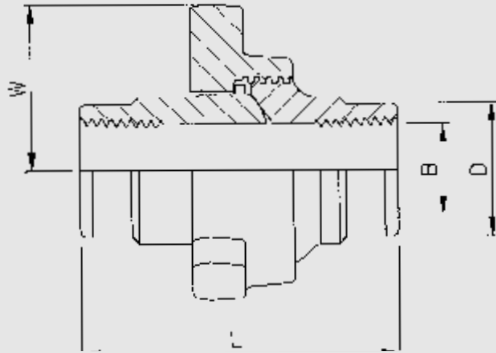

Fig 100 Union

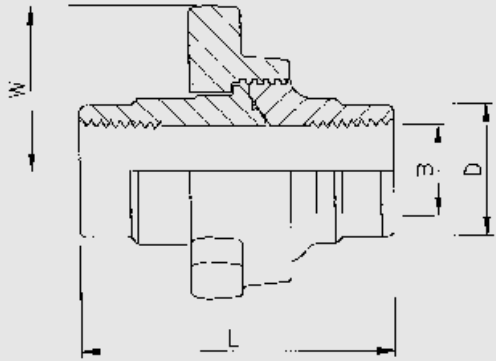

Fig 200 and 206 Union

Table 7.1 Figure 100 Union

Nominal Pipe Size		W.Nut Radius	D. Outside Diameter	L. End to End Threaded	B. Max Inside Diameter	Weight
(in)	(mm)	(mm)	(mm)	(mm)	(mm)	(kg)
2	50	81	73	92	55	2.40
2 1/2	65	92	83	109	65	3.60
3	80	102	102	124	81	6.4
4	100	120	132	146	106	10.50
6	150	166	186	171	160	20
8	200	199	241	183	209	27.70

Table 7.2 Figure 200 and 206 Union

Nominal Pipe Size		W.Nut Radius	D. Outside Diameter	L. End to End Threaded	B. Max Inside Diameter	Weight
(in)	(mm)	(mm)	(mm)	(mm)	(mm)	(kg)
1	25	50	40	66	28	0.80
1 1/4	32	61	51	71	37	1.00
1 1/2	40	61	57	71	43	1.00
2*	50	74	74	90	55	2.30
2 1/2	65	92	84	105	65	4.50
3	80	108	104	115	81	6.90
4	100	127	130	127	106	9.10
6	150	165	191	169	160	19.30
8	200	198	243	183	209	29.10
10	250	230	292	231	262	41.36

Section 7. Hammer Lug Unions

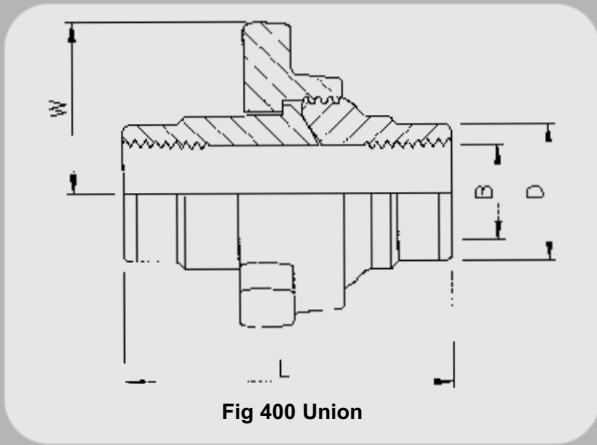

**Table 7.3 Figure 400 Union**

Nominal Pipe Size		W.Nut Radius	D. Outside Diameter	L. End to End Threaded	B. Max Inside Diameter	Weight
(in)	(mm)	(mm)	(mm)	(mm)	(mm)	(kg)
2	50	90	78	133	55	5.00
2 1/2	65	108	89	157	65	8.30
3	80	108	106	157	81	8.75
4	100	127	133	209	106	14.50
5 1/2	140	148	159	276	129	22.00
6	150	171	197	281	160	29.00
7	175	171	197	281	158	28.00
8	200	198	244	291	209	43.00
10	250	244	298	270	262	68.00
12	300	272	356	278	313	74.00

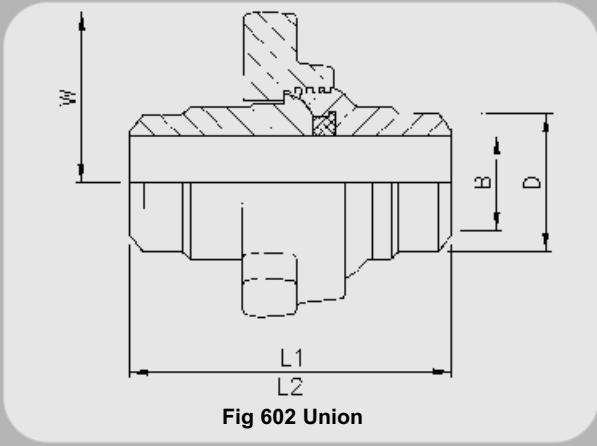

**Table 7.4 Figure 602 Union**

Nominal Pipe Size		W.Nut Radius	D. Outside Diameter	L1. End to End Threaded	L2. End to End Butt Weld*	B. Max Inside Diameter	Weight
(in)	(mm)	(mm)	(mm)	(mm)	(mm)	(mm)	(kg)
1	25	55	33	90	90	28	1.59
1 1/4	32	82	42	124	124	36	4.54
1 1/2	40	82	48	124	119	43	4.10
2	50	95	60	133	128	52	5.90
2 1/2	65	108	73	156	143	65	8.20
3	80	114	89	159	138	81	10.45
4	100	132	114	210	134	106	15.00

\* SCH 160

Outside Diameter D based upon Nominal Pipe Sizes

## Section 7. Hammer Lug Unions

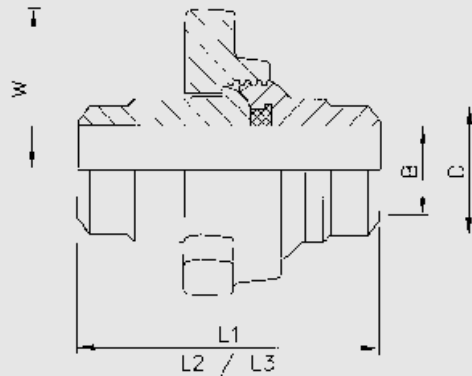

**Fig 1004 Union**

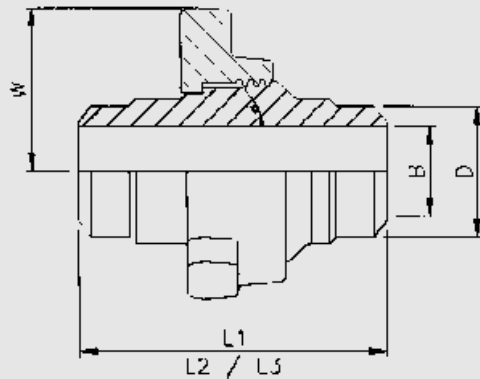

**Fig 1002 (5" & 6" only) o-Ring**

**Table 7.5 Figure 1002/1004 Union**

Nominal pipe size		W.Nut Radius	D. Outside Diameter	L1. End to End Threaded	L2. End to End Butt Weld*	L3. End to End Butt Weld**	B. Max Inside Diameter	Weight
(in)	(mm)	(mm)	(mm)	(mm)	(mm)	(mm)	(mm)	(kg)
1	25	60	33	90	90	90	28	1.60
1 ¼	32	81	42	124	-	124	36	4.30
1 ½	40	81	48	124	119	124	43	4.00
2	50	95	60	133	127	132	52	6.00
2 ½	65	108	73	156	156	159	65	7.95
3	80	125	89	159	138	145	77	10.00
4	100	133	114	210	140	144	102	17.95
5	125	156	141	-	♦♦ 152	156	-	♦♦25.00
6	150	178	168	-	♦♦ 159	♦♦165	-	♦♦36.00

\* SCH 160    \*\* SCH XXS

Referred to as lipseal or sometimes referred to as 1004  
 These figures are approximate only. Please consult RB Pipetech for exact dimensions and specifications.

Outside Diameter D based upon Nominal Pipe Sizes

**Table 7.6 Figure 1002/1004 Union**

Nominal pipe size		W.Nut Radius	D. Outside Diameter	L1. End to End Threaded	L2. End to End Butt Weld*	L3. End to End Butt Weld**	B. Max Inside Diameter	Weight
(in)	(mm)	(mm)	(mm)	(mm)	(mm)	(mm)	(mm)	(kg)
5	125	156	141	-	152	156	-	25.00
6	150	178	168	-	159	165	-	36.00

\* SCH 160    \*\* SCH XXS

Outside Diameter D based upon Nominal Pipe Sizes

## Section 7. Hammer Lug Unions

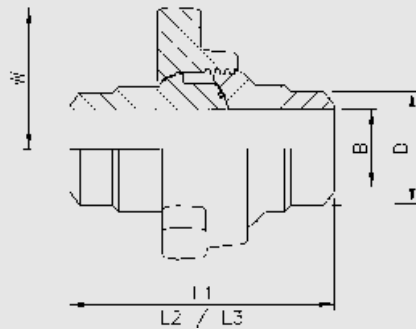

**Fig 1003 Union**

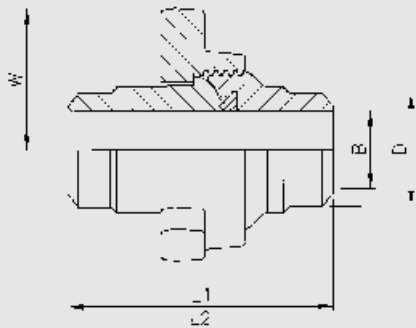

**Fig 1502 Union**

**Table 7.7 Figure 1003 Union**

Nominal Pipe Size		W.Nut Radius	D. Outside Diameter	L1. End to End Threaded	L2. End to End Butt Weld*	L3. End to End Butt Weld**	B. Max Inside Diameter	Weight
(in)	(mm)	(mm)	(mm)	(mm)	(mm)	(mm)	(mm)	(kg)
2	50	95	60	121	117	121	50	5.40
3	80	124	89	232	225	232	81	20.00
4	100	146	114	278	271	278	101	33.00
5	125	146	141	-	273	278	-	33.00

\* SCH 160 \*\* SCH XXS

Outside Diameter D based upon Nominal Pipe Sizes

**Table 7.8 Figure 1502 Union**

Nominal Pipe Size		W.Nut Radius	D. Outside Diameter	L1. End to End Threaded	L2. End to End Butt Weld**	B. Max Inside Diameter	Weight
(in)	(mm)	(mm)	(mm)	(mm)	(mm)	(mm)	(kg)
1	25	73	33	110	110	28	3.60
1 1/2	40	93	48	137	137	43	5.40
2	50	99	60	178	159	51	8.70
2 1/2	65	106	73	184	-	65	10.00
3	80	114	89	194	130	77	13.00
4	100	150	114	216	216	103	34.00
5	125	165	141	-	-	101	50.00
6	150	185	168	-	250	124	♦♦73.00

\*\* SCH XXS

- ◆ Special sizes available from GonPetro
- ◆◆ These figures are approximate only. Please consult GonPetro for exact dimensions and specifications.

Outside Diameter D based upon Nominal Pipe Sizes

## Section 7. Hammer Lug Unions

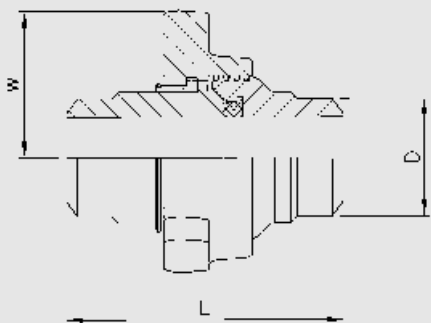

**Fig 2202 Union**

**Table 7.9 Figure 2202 Union**

Nominal Pipe Size		W.Nut Radius	D. Outside Diameter	L. End to End Butt Weld	Weight
(in)	(mm)	(mm)	(mm)	(mm)	(kg)
2	50	95	65	188	12.00
2 ½	65	115	105	243	19.00
3	80	159	140	267	25.00